

H300KS-13 Stainless Steel Edge Rail Channel System

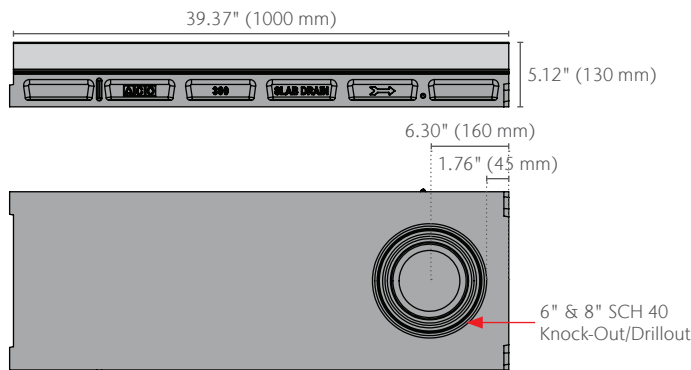

H300KS-13 Neutral Channel

Part No. 93465



H300KS-13 Closing End Cap

Part No. 93469



Outlet Flow Rates

Outlet Flow Rates	Outlet Size (SCH 40)	Invert Depth in (mm)	GPM	CFS
H300KS-13 Neutral Channel - 39.37" (1000 mm)	6" round	4.00 (102)	243	0.54
H300KS-13 Neutral Channel - 39.37" (1000 mm)	8" round	4.00 (102)	432	0.96

These are the pipe flow rates at the specified outlet, NOT channel flow rates

Products

Description	Part No.	Invert Depth in (mm)	Weight lbs
H300KS-13 Neutral Channel - 39.37" (1000mm)	93465	4.00 (102)	71.6
H300KS-13 Closing Cap	93469	4.00 (102)	1.0

1. Add nominal 0.6" (15 mm) to invert depth for overall channel depth
2. Preformed 6" & 8" SCH 40 knock-out cast on underside of each channel
3. Use grate removal tool to remove grates (Part No. 01318)

H300KS-13 Stainless Steel Edge Rail Channel System



Specification Summary

General

The surface drainage system shall be ACO Drain SlabDrain H300KS-13 complete with gratings secured with QuickLok® as manufactured by ACO, Inc. or equal approved.

Grates

Grates should be specified. See separate ACO Spec Info grate sheets for details. After removal of grates and QuickLok bar there shall be uninterrupted access to the trench to aid maintenance.

Installation

The trench drain system shall be installed in accordance with the manufacturer's installation instructions and recommendations.

Materials

The trench system bodies shall be manufactured from polyester polymer concrete with minimum properties as follows:

- Compressive strength: 14,000 psi
- Flexural strength: 4,000 psi
- Water absorption 0.07%
- Frost proof
- Salt proof
- Dilute acid and alkali-resistant

The nominal clear opening shall be 11.81" (300mm) with overall width of 14.17" (360mm). Pre-cast units shall be manufactured with neutral invert and have a wall thickness of at least 0.5" (13mm). Each unit will feature a male to female interconnecting end profile. Units shall have horizontal cast in anchoring features on the outside wall to ensure maximum mechanical bond to the surrounding bedding material and pavement surface. The stainless steel edge rail will be integrally cast in by the manufacturer to ensure maximum homogeneity between polymer concrete body and edge rail. Each edge rail shall be at least 1/8" (3mm) thick.



EN1433 Load Class E
134,885 lbs – 2,785 psi

ACO, Inc.

© January 2026 ACO, Inc.

All reasonable care has been taken in compiling the information in this document. All recommendations and suggestions on the use of ACO products are made without guarantee since the conditions of use are beyond the control of the company. It is the customer's responsibility to ensure that each product is fit for its intended purpose and that the actual conditions of use are suitable. ACO, Inc. reserves the right to change products and specifications without notice.

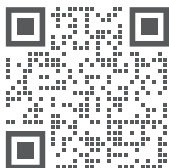

info@acousa.com
www.acousa.com

